

# Total solar radiation sensor (Class A)

## Model ES-S228T-A

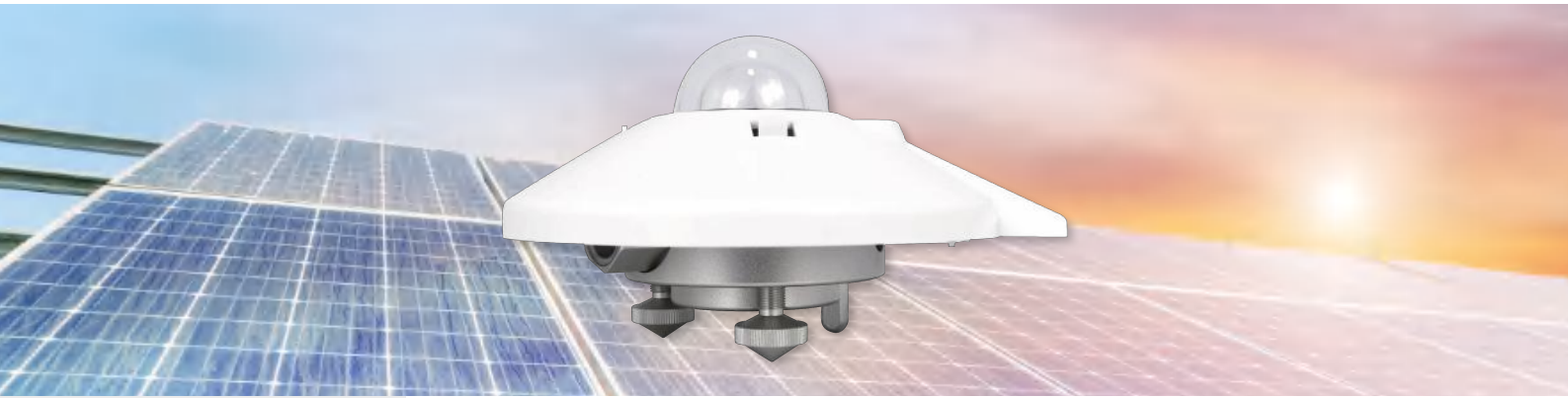

### Main features

- Meets Class A standards according to ISO9060 and VMO technical specifications.
- Utilizes high-precision thermopile semiconductor processing technology for enhanced accuracy.
- A high-quality 1mm protective cover and fully enclosed design prevent interference
- Allows all-weather data calibration, suitable for sunny, cloudy, and overcast conditions

### Compliance

The electromagnetic compatibility in accordance with the following applicable directives:  
 LVD 2014/35/EU Low Voltage  
 EMC 2014/30/EU  
 Electromagnetic Compatibility  
 EMC 2014/35/EU  
 Electromagnetic Compatibility

### Introduction

The ES-S228T-A series total radiation sensor is a shortwave total radiation sensor used for solar radiation observation. It is a Class A total radiation sensor conforming to the latest ISO 9060 and WMO technical standards. It measures solar radiation received by a horizontal plane from a solid angle of 2 T steradian degrees (hemispherical), with units of W/m'.

The ES-S228T-A series total radiation sensor operates in a completely passive mode, utilizing a thermopile sensor to generate an output voltage proportional to the incident radiation flux. Due to the use of two spherical glass domes, measurement errors, especially thermal offset, are reduced, resulting in high measurement accuracy.

### Application

Used for meteorological observation, building physics, climate, and solar energy harvesting experiments. A common application is as part of a weather station to measure outdoor solar radiation.

### Dimension

Unit:mm

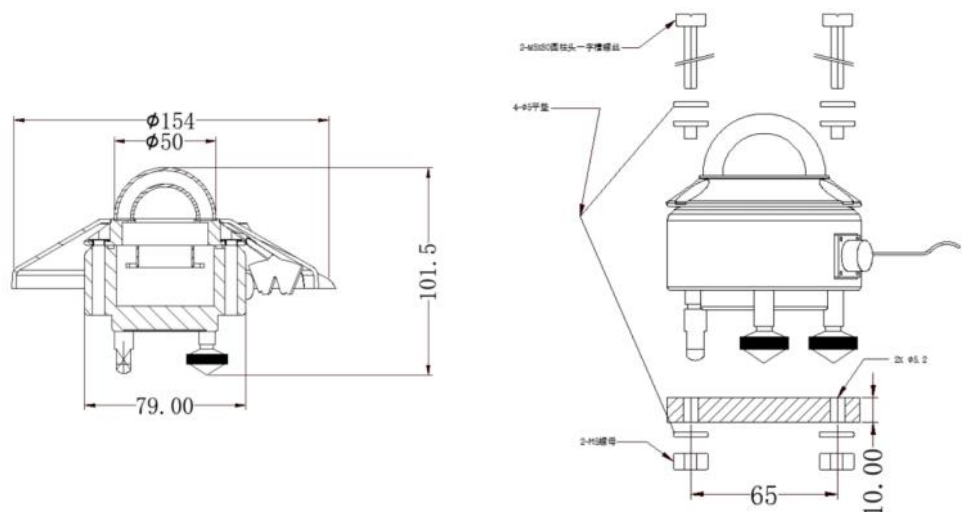

## Specification

|  |  |
|--|--|
| Classified according to ISO 9060/WMO standards   | Grade A/Good Quality   |
| Response time (95% response)   | <5s  |
| Zero-point offset: Corresponding to 200 W/m <sup>2</sup> net thermal radiation (ventilation) | <7 W/m <sup>2</sup>  |
| Stability (Variation/Year, Percentage of Full Scale)   | ±0.5%  |
| Nonlinearity   | ±0.2%(100~1000 W/m <sup>2</sup> )  |
| Directional Response   | ±10 W/m <sup>2</sup>   |
| Temperature Response   | <1%(-10~40°C)  |
| Tilt Response  | <0.5%  |
| Sensitivity Range  | 7-14μV/(W/m <sup>2</sup> )   |
| Operating Temperature  | -40~+80°C  |
| Internal Resistance  | <50Ω   |
| Standard Cable Length  | 3m   |
| Measurement Range  | 0~4000W/m <sup>2</sup>   |
| Cable Replacement  | Users can remove and install cables  |
| Spectral Range   | 280~3000 nm (50% transmittance)  |
| Reading Requirements   | One differential voltage channel or one single-ended voltage channel               |
| Horizontal Calibration   | Includes bubble level and adjusting feet   |
| Solar Exposure Uncertainty   | ±1%  |
| Weight (excluding cable)   | 0.8kg  |
| Calibration Traceability   | WRR traceability, procedure according to ISO9847                                   |
| Recommended Calibration Cycle  | Biennially   |
| Output Signal  | Original output 0~20mV,Optional RS485/4~20mA output (not for external transmitter) |

## Order guide

|            |                        |  |               |
|------------|------------------------|--|---------------|
| ES-S228T-A | Solar radiation sensor |  |               |
|            | CODE                   | Material                               |               |
|            | A                      | Total solar radiation sensor (class B) |               |
|            |                        | CODE                                   | Signal output |
|            |                        | 1                                      | 0-20mA        |
|            |                        | 2                                      | 4-20mA        |
|            |                        | 3                                      | RS485         |
| ES-S228T-A | A                      | 1                                      | Order example |